

# MN1818 Evaluation Kit v3 User Guide



## 1 Evaluation Kit Introduction

The MN1818 Evaluation Kit is designed to allow the user to quickly evaluate the Micro Modular Technologies MN1818 GPS receiver module. This kit can be used in either a laboratory or a mobile environment. The MN1818 Evaluation Kit implements the necessary circuitry to attach an MN1818 GPS receiver module to a PC-compatible computer. In addition, the Evaluation Kit provides the necessary power for the supplied active antenna.

The MN1818 Evaluation Kit software is supplied on a CD ROM. This software is installed onto the PC-compatible computer. This software allows the user to control the MN1818 GPS receiver module as well as display and record the receiver output message data.

### 1.1 Document Applicability

This document applies to Version 3 of the MN1818 Evaluation Kit (MN1818-3EVK).

### 1.2 Kit Identification

The version of the Evaluation Kit can be identified as follows:

- Ver. 1 – not placed in production
- Ver. 2 – 76 mm x 140 mm size
- Ver. 3 – 135 mm x 148 mm size

## 2 Description of the Evaluation Kit

The MN1818 Evaluation Kit features dual RS-232D level translation from the logic levels utilized by the MN1818 GPS Receiver module to the RS-232D levels typically used for serial data communications with the PC-compatible computer.

In addition, the MN1818 Evaluation Kit features an active antenna power supply to provide power to an external active antenna, several internal DC power supplies which are used to provide the necessary power to the MN1818 itself, as well as the ancillary circuitry on the MN1818 evaluation board.

Switching power supplies were chosen for the main power supplies to improve the battery life of the internal battery pack. Also, switching power supplies more closely represent power supplies that would most likely be chosen by an OEM.

Version 3 of the MN1818 Evaluation Kit includes a Real Time Clock chip onboard which is supplied with backup power even when the main power switch is turned off. This provides the MN1818 receiver with precise time which allows the receiver to execute a hot start (assuming that ephemeris and position data is current). The user can therefore evaluate the Hot Start capability of the MN1818.

### 2.1 Supplied Equipment

The MN1818 Evaluation Kit contains the following items:

1. MN1818 GPS receiver module installed onto an the evaluation board which includes RS-232 level translators, power supplies and switches.
2. MN1818 Evaluation Kit CD which contains the following:
  - a. MMT Evaluation Software for operation of the MN1818 Evaluation Kit

# MN1818 Evaluation Kit v3 User Guide



- b. Documentation for the MN1818 Evaluation Kit in PDF format.
- 3. Serial Cable
- 4. Four AA Batteries
- 5. Active Patch Antenna

## 2.2 Additional Required Equipment

The MN1818 Evaluation Kit requires the following customer-supplied items at a minimum for testing the MN1818 GPS receiver module:

- 1. PC-compatible desktop or laptop (preferred) equipped with the Windows XP operating system, one available serial port and a CD ROM drive.

## 2.3 Detailed Interfaces Description

### 2.3.1 Indicator Lights

Three indicator lights are provided on the faceplate to provide summary status of the MN1818 evaluation board.

- The leftmost light is the PWR light, which illuminates when DC power is active within the MN1818 evaluation board.
- The middle light is the DATA light, which flashes to indicate the MN1818 evaluation board is sending RS-232 data to the host computer on Port 0.
- The rightmost light is the 1PPS light, which flashes at a 1 Hz rate driven by the 1PPS signal from the MN1818 GPS Receiver module when the receiver has a fix.

### 2.3.2 Serial Port 0

Serial Port 0 is the primary serial port for communications between the MN1818 evaluation board and the PC-compatible computer. When viewed from the front (switch and LED end), serial port 0 is on the right side of the board. Communications on this port are in National Marine Electronics Association (NMEA-0183) format for both data and configuration messages. The pin configuration for serial port 0 is defined in

Table 1. The signal levels are defined in EIA-RS-232D.

Pin Number	Function	Signal Direction
2	Tx Data	From MN1818 to computer
3	Rx Data	From computer to MN1818
5	Signal Return	Connect to DC return

Table 1 – RS-232 Pin Assignments

# MN1818 Evaluation Kit v3

## User Guide

---



### 2.3.3 Serial Port 1

Serial Port 1 is the secondary port for communications between the MN1818 evaluation board and the PC-compatible computer. This port can be used for binary communications protocol.

The pin assignment and signal levels are the same as shown for serial port 0.

### 2.3.4 Antenna connector

The antenna connector provides the L1 GPS signal from an antenna into the MN1818 evaluation board. Both active and passive antennas are supported and the MN1818 Evaluation Kit includes an active antenna.

If a directly-connected, 3-volt active antenna is not going to be used, the antenna supply voltage must be disabled by inserting a DC block in the antenna circuit.

### 2.3.5 Power Switch

The leftmost switch on the face of the MN1818 evaluation board is the power switch which controls power to the evaluation board. If the switch is in the lower position, the power is turned off to the evaluation board. Note that the switch does not interrupt the DC power, but places the onboard power supplies into shutdown mode. Therefore, there is a very small amount of leakage current drawn from the DC power source.

### 2.3.6 Serial Boot Switch

The middle switch controls serial boot and is used to reprogram the flash memory on board the MN1818 GPS Receiver module. For normal operation with program execution from flash, this switch should be in the up position.

The position of this switch is only read upon power up or reset of the MN1818 GPS Receiver module. Changing the switch position at other times has no effect on the operation of the receiver.

### 2.3.7 Reset Button

The rightmost switch, a reset button, issues a hardware reset command to the MN1818 GPS Receiver module. This button is used during programming, or whenever the user desires to issue a hardware reset to the MN1818 module.

## 3 Configuring the Evaluation Kit

As shipped, the MN1818 Evaluation Kit is useable without having to reconfigure internal options. The default configuration applies 3 volts DC superimposed upon the RF antenna connection to supply power to the included active antenna. If passive antenna operation is desired, the antenna supply voltage must be disabled by inserting a DC block in the antenna circuit.

# MN1818 Evaluation Kit v3

## User Guide



### 3.1.1 Jumpers

- J5 jumper block on the MN1818 evaluation board is provided to allow the insertion of a DC current meter to measure the DC current being supplied to the MN1818. During normal operation a shunt should be connected across the two pins of J5.
- J9, J10, J11, J99 jumper blocks on the MN1818 evaluation board are provided to disconnect the Real Time Clock if desired. These jumper blocks should have a shunt installed unless the kit is to be used without the RTC active.

### 3.1.2 Battery Pack

The battery pack allows for the installation of four AA-size batteries. Battery orientation is molded into the plastic case.

The internal batteries can provide power for up to approximately 75 hours before the batteries are exhausted. If the MN1818 evaluation board is not to be used on internal batteries for more than two weeks, remove the batteries to avoid the possibility of electrolyte leakage from the battery. Although rechargeable batteries may be used in the MN1818 evaluation board, the kit provides no means to recharge the batteries. In addition, rechargeable batteries will have a shorter life than standard alkaline cell batteries. The MN1818 evaluation board contains protection diodes to prevent damage in case the batteries are inserted incorrectly.

## 4 Initial Checkout of the MN1818 Evaluation Kit

Follow this procedure to initially check out the proper operation of the software and MN1818 Evaluation Kit hardware.

1. Install four AA batteries into the MN1818 evaluation board.
2. Turn on the power switch on the MN1818 evaluation board and verify the power LED glows green. If the LED does not glow green, make sure shunt J5 is installed.
3. Turn off the power switch.
4. Connect the supplied serial cable from Port 0 of the MN1818 evaluation board to the serial port of the host PC.
5. Connect the active antenna to the RF connector on the MN1818 evaluation board.
6. Place the active antenna where it has a clear and unobstructed view of the open sky.
7. Start up the MN1818 evaluation program on the host computer.
8. Turn on the power switch of the MN1818 evaluation board.
9. The MN1818 evaluation program should indicate communication with the MN1818 evaluation board, and after a short delay of a minute or so display current time and position.
10. Allow the receiver to operate for approximately 15 minutes to collect current almanac data from the GPS satellites.

# MN1818 Evaluation Kit v3 User Guide



## 5 Evaluation Board Layout

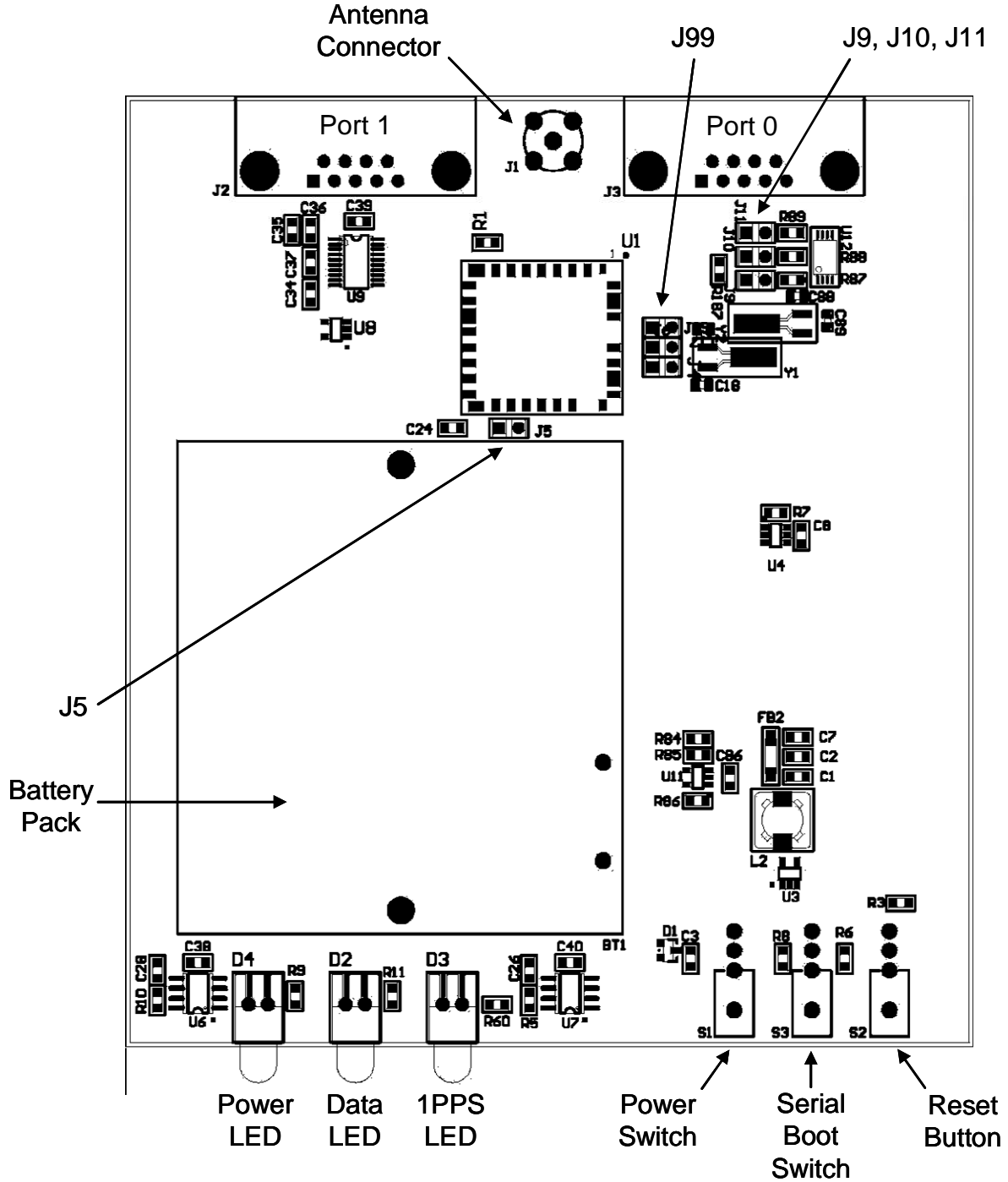

Figure 1 – MN1818 v3 Evaluation Board Layout

# MN1818 Evaluation Kit v3 User Guide



## 6 Evaluation Board Schematic

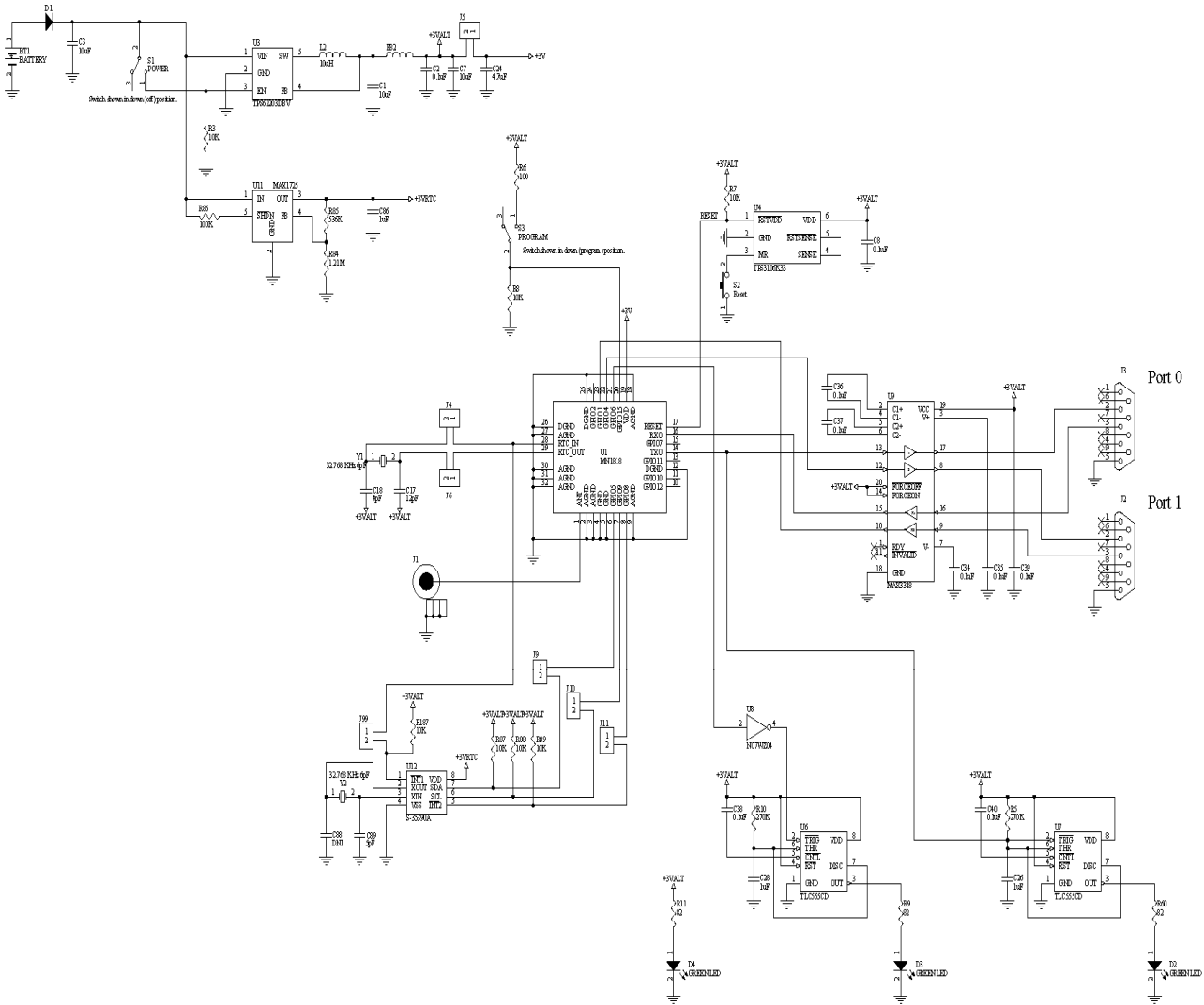

Figure 2 – MN1818 v3 Schematic

# MN1818 Evaluation Kit v3 User Guide

---



## 7 Notices

All reference and informational documents (including marketing information, specifications, reference designs, etc.) are provided for information only and are subject to change without notice. Reasonable efforts have been made in the preparation of these documents to assure their accuracy, however Micro Modular Technologies Pte. Ltd. assumes no liability resulting from errors or omissions in these, or any document, or from the use of the information contained herein. Micro Modular Technologies Pte. Ltd. reserves the right to make changes in the product design and specifications as needed and without notification to its users. Please check our website for the most current documentation. All information contained herein is the property of Micro Modular Technologies Pte. Ltd. and may not be copied or reproduced, other than for your information, without prior written consent.

## 8 Contact Information

### Corporate Headquarters

Micro Modular Technologies Pte. Ltd.  
No. 3, Ubi Avenue 3, #05-01  
Crocodile House, Singapore 408857

Tel: (65) 6745 8832  
Fax: (65) 6293 0661  
Email: [sales@micro-modular.com](mailto:sales@micro-modular.com)

### Americas and Europe

Micro Modular Technologies Americas  
14720 Creekside Lane  
Longmont, CO 80503, U.S.A.

Tel: (1) 303-482-2842  
Fax: (1) 303-339-0398  
Email: [sales@micro-modular.com](mailto:sales@micro-modular.com)

For a list of Regional Sales Representatives,  
please see our web page:  
[www.micro-modular.com](http://www.micro-modular.com)