

MN5310HS/AHS Design Guidelines

1 Introduction

This document contains important technical information, design notes and helpful hints to assist the designer in achieving first time success in bringing up a design using the MN5310HS/AHS GPS Receiver module. It contains design examples and suggestions on a wide variety of topics, including power supply connections and bypassing, RF interface design, shielding and filtering requirements, antenna considerations and other important subjects.

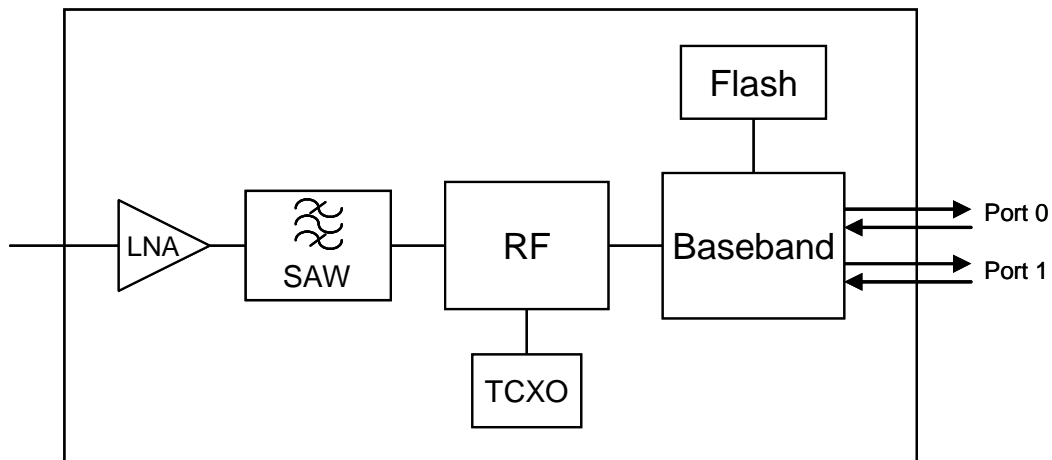

Figure 1 - MN5310HS/AHS Block Diagram

2 Power Supply

The MN5310HS/AHS GPS Receiver Module is designed to operate directly from a single supply voltage with a range of 3.0 volts DC minimum to 3.6 volts DC maximum. If the primary power supply is removed, VBK (also 3.0 to 3.6 VDC) should be present in order to keep the internal RTC clock and SRAM alive, even when the receiver is in hibernate mode. If both VCC and VBK are removed, a factory start will be performed upon power-up. VBK must be supplied whenever VCC is applied.

2.1 On-Off Control

Power is controlled via the ON-OFF signal pin of the MN5310HS/AHS . If this line is left floating or tied to ground, the receiver will power up and run continuously whenever VCC (and VBK) are applied. Although VCC and VBK could be switched off to completely power down the receiver, all data stored in the receiver's RAM will be lost, with the following results:

- Internal TCXO calibration data is lost, lengthening the time for a cold start.
- The current time is lost, eliminating the possibility of a hot start or warm start.
- The current location is lost, eliminating the possibility of a warm start.
- Current ephemeris data is lost, requiring download of the latest ephemeris data.
- Current almanac data is lost so the receiver will revert to the factory almanac.
- Patch RAM contents (if any) are lost and will require a new download.

MN5310HS/AHS

Design Guidelines

To place the receiver into hibernate state (all internal power supplies other than RTC and SRAM off) from the full power operating (ON) state, pulse the On-Off control high for a minimum of 1 millisecond. To return the receiver to full power operate state from the hibernate state, pulse the On-Off control high for a minimum of 1 millisecond. The Power On-Off pulse must not occur more than once per second.

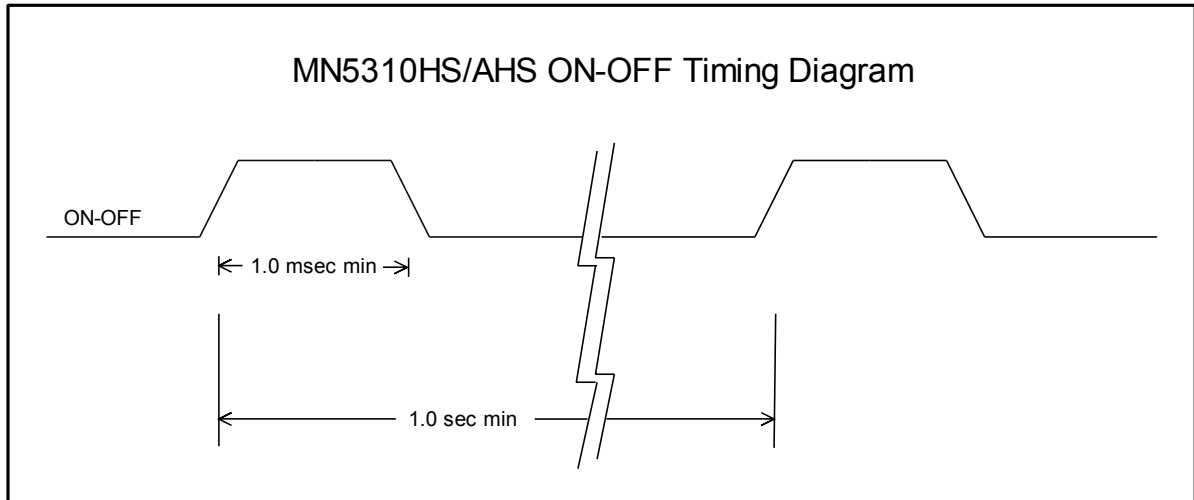

Figure 2 - ON-OFF Signal Timing

If the receiver is operating in one of the power management modes (Adaptive Trickle Power or Push-To-Fix mode), use the software commands to return the receiver to full power operating mode before sending the On-Off pulse. Sending an On-Off pulse during ATP or PTF mode could result in an undetermined power state. Do not apply an On-Off pulse to the MN5310HS/AHS if VCC (and VBK) are not present.

The internal ON-OFF signal is a 1.8 volt logic level. A series resistor of 10K and a shunt resistor to ground of 10K to the internal ON-OFF node reduces the 3 volt external logic level to this 1.8 volt internal logic level. This network must be taken into account if designing an external resistive divider network to interface the 3 volt logic level ON-OFF signal to a higher voltage I/O controller.

3 Serial Data Lines

3.1 TX Data Line

The TX data line outputs serial data from the MN5310HS/AHS receiver to the host. This signal is a 2.85 volt CMOS I/O logic level with the idle condition being logic high.

During hibernation, the TX data line will be at 0 volts. The user is cautioned to ensure that any downstream processing of this signal can tolerate a 0 volt condition (BREAK condition) whenever the MN5310HS/AHS is in hibernate state.

3.2 RX Data Line

The RX data line is used to input commands from a host to the MN5310HS/AHS receiver. This signal is a 2.85 volt CMOS I/O logic level with the idle condition being logic high.

During hibernation and when primary power (VCC) is not present, take care not to drive this line high (the normal default idle state of this signal) to prevent partially powering the MN5310HS/AHS by back-driving the ESD diode protection circuitry. Do not hold this line low (BREAK state) while the receiver is active. Its idle state should be HIGH.

MN5310HS/AHS

Design Guidelines

4 1PPS Pin

The 1PPS signal pulses high for 1 microsecond at a 1 Hz rate. It is synchronized when the fix is valid. The 1PPS signal can vary by up to 200 nanoseconds and trails the UTC 1 second epoch by 450 nanoseconds.

5 BOOT Pin

The BOOT pin must be grounded, preferably through a zero Ω resistor allowing the flash to be re-programmed in the future if that should be required..

6 RF Interface

6.1 RF Input

The MN5310HS/AHS GPS Receiver Module accepts a standard L1 GPS C/A code signal (from a passive or active antenna) on the RF Input pad of the module. If a passive antenna is desired, no additional circuitry is required.

6.2 Passive Antenna

A passive antenna can be directly connected to the RFIN input of the MN5310HS/AHS . Assuming the antenna is well tuned for the ground plane it would sit on and any plastics that would enclose it, matching of the antenna to the MN5310HS/AHS would not be required. However, good practice suggests that footprints for a PI matching network would be prudent if space permits.

The RFIN input to the MN5310HS/AHS directly feeds an LNA. If high levels of RF interference are expected in the end product, the addition of a pre-select SAW or ceramic filter may be required to provide good performance.

The rejection characteristics of the pre-select filter can be determined by measuring the out-of-band signal levels and using the values from the jamming curve of the MN5310HS/AHS as shown in the data sheet.

6.3 Active Antenna

If an active antenna is required, then suitable means for powering the active antenna must be provided external to the MN5310HS/AHS GPS Receiver Module. DC power may be supplied to an active antenna via the VANT pin (pin 19). If desired, the VRF pin (pin 20) can be connected to VANT to supply 2.85 VDC at 15 mA (max) to the antenna. The RF input is isolated from DC levels to a maximum of ± 15 V. In addition, depending upon the amplifier gain of the active antenna (not to be confused with antenna gain) and cable loss, an RF attenuator may need to be inserted in front of the MN5310HS/AHS to attenuate the output of the active antenna. Generally, an excess gain greater than 14 dB will need to be attenuated to bring the total gain in front of the MN5310HS/AHS down to 14 dB. Operating with higher gain is possible, but may result in somewhat degraded performance in interference rejection.

If tolerance to high levels of RF interference is required in the end product, the active antenna can be selected to have both a pre-select and post-select filter to attenuate the unwanted interference.

6.4 LO Leakage

The MN5310HS/AHS has an internal LO at 1571.424MHz that can appear at the RFIN pad of the device. While this level is quite low (approximately -80 dBm), it is high enough that it could interfere with another GPS receiver in the vicinity. This is not a problem in normal operation, but during test

MN5310HS/AHS

Design Guidelines

and evaluation, several receivers could be operating simultaneously from a common antenna or other signal source. In this case, care must be taken to provide proper isolation between the receivers.

6.5 Spurious Signals

Due to the tight IC geometries used internally, the MN5310HS/AHS does generate a fair amount of digital noise. Since this is all based upon the internal reference frequency of 16.369 MHz, it is synchronous within the receiver and does not impact receiver operation. However, some signals may interfere with external circuitry. Therefore, it may be necessary to shield the GPS module and related circuitry from other receivers in the end product.

7 Shielding and Filtering Requirements

The MN5310HS/AHS is designed to use a GPS signal that can be as low as -159 dBm. Any source of interference near in frequency to the GPS signal could potentially jam the MN5310HS/AHS and disrupt reception of the signal.

7.1 Digital Emissions

For proper system design, the GPS antenna needs to be shielded from any potential jamming source. For that reason, in most designs not containing a transmitter it makes more sense to shield the digital portion of the product rather than the RF portion. This keeps the digital noise from radiating into the antenna and/or antenna feed line. Generally, it is not necessary to provide additional shielding around the MN5310HS/AHS and associated circuitry.

It is important to note the GPS signal level is well below any regulatory emissions requirement for EMI and EMC. Thus while a product meets FCC class B or CISPR 22, it is possible the emissions from the product will still seriously impact the MN5310HS/AHS performance.

Excessive interference into the MN5310HS/AHS via the antenna can result in low to very low reported C/Nos of the satellite signals and consequent lengthened TTFF times. Assuming an 18mm square patch antenna with good LNA and a clear view of the sky, the reported C/Nos should be in the high 40s. If the values are below this, then interference needs to be considered as a problem and resolved. This can also be checked by connecting an external active antenna and moving it closer to and further away from the device while noting the change in reported C/Nos. If any improvement in signal is noted as the external antenna is moved away from the device, then additional shielding is required.

7.2 RF Emissions

If the product contains an RF transmitter or another heterodyne receiver, then care must be taken to prevent overloading the front end of the MN5310HS/AHS if simultaneous operation is required. This overloading can come from several sources.

First, the input LNA on an active antenna may not have a preselect filter and is fairly broad band. If, for example a GSM transmitter (1.8 GHz) were close by, then the GSM signal could overload the LNA. The output of the LNA is going to be proportional to its input, and if the GSM signal so dominates, the GPS signal would be attenuated and sensitivity of the receiver would be reduced. The OEM designer would need to include suitable input filtering to the MN5310HS/AHS to avoid this situation.

A second case occurs in the collocated transmitter. The power amplifier has both a gain and a noise figure. If we take an example of a power amp noise figure of 15 dB and 30 dB of gain, this would mean that the power amp radiates broadband noise approximately 45 dB above thermal noise. This means the power amp alone could present a noise source in the GPS band of -129 dBm. While this would easily meet any regulatory emissions requirements, it would render the GPS receiver

MN5310HS/AHS

Design Guidelines



inoperative. In this case, a suitable filter must be placed on the output of the power amplifier of the collocated transmitter, not the GPS receiver, to avoid this situation.

8 GPS Antenna Selection

Currently, there are several types of GPS antennas available for the user to choose from. Each type of antenna has both advantages and disadvantages which need to be carefully weighed in making a selection. In addition, most antenna types are available in both an active version (which includes a built in LNA) and passive version. The MN5310HS/AHS is designed to use an active antenna.

When selecting the antenna, it is important to consider the characteristics of the GPS signal itself as well as the characteristics of the antenna. The GPS signal is broadcast at 1.57542GHz and comes from each of the visible GPS satellites. The receiver needs a minimum of four signals to compute a 3D position. Ideally, the antenna should have an unrestricted view of the sky. Certain locations may limit the visibility of the sky such proximity to a building, etc, so it is important that the product in which the antenna is installed does not further obscure satellite visibility.

The GPS signal is right hand circularly polarized (RHCP), so best results are achieved (under most conditions) with a right hand circularly polarized antenna. Under severe obscuration, where multipath signal reflections are present, a linearly polarized antenna may give better results under the assumption that a reflected signal is better than no signal.

Antennas are specified by antenna type, antenna gain, antenna pattern, polarization and axial ratio. Three common antenna types are covered in the next sections. Antenna gain is the ratio of the signal level received by the antenna under consideration at zenith as compared to a theoretical isotropic radiator (one with equal signal levels in all directions). The gain is measured in dBi for a linearly polarized antenna or dBic for a circularly polarized antenna. The gain of an antenna will vary depending upon the direction (elevation and azimuth) of the signal source with respect to the antenna and an antenna pattern is a graphical plot of this variation. The axial ratio of an antenna is a measure of the quality of its polarization. An axial ratio of 1 is perfect circular polarization, and an infinite axial ratio is perfectly linear polarization.

MN5310HS/AHS

Design Guidelines

8.1 Patch Antennas

Patch antennas are typically square or round ceramic elements with metallic plating on both sides, the top being the antenna element and the bottom being the ground plane.

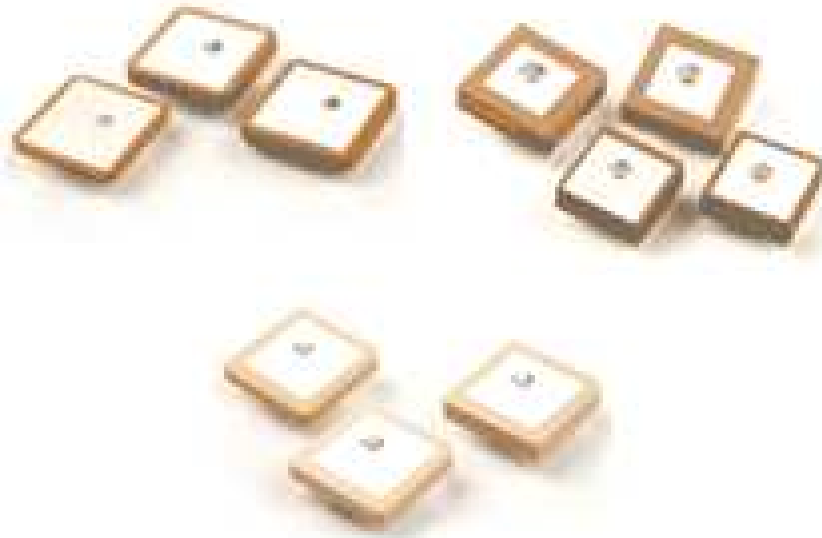

Figure 3 – Typical patch antennas

If a patch antenna is selected, it is important that it be oriented such that the top surface of the antenna is horizontal with respect to the surface of the earth. Tilting the antenna away from the horizontal will result in an artificial obscuration of potentially visible satellites.

While patch antennas are low cost and can provide good gain, it is important that they be used with a proper ground plane. The antenna vendor can provide assistance in this area. In addition, a patch antenna is detuned by the presence of anything within its near field, such as a plastic cover. The antenna vendor can tune the antenna to compensate for this detuning.

MN5310HS/AHS

Design Guidelines

8.2 Helix Antennas

Helix antennas consist of spirally wound elements on a tubular substrate of ceramic or other material (see Figure 4). For best performance, the helix antenna should be oriented vertically with respect to the surface of the earth. Helix antennas do not require a ground plane, but may work better with one.



Figure 4 – Sarantel helix antenna (cover removed)

8.3 Chip Antennas

Chip antennas are the smallest type available for GPS and are quite popular in small handheld devices. However, chip antennas are linearly polarized, giving them a 3 dB disadvantage and making them more receptive to multipath signals (which could degrade the accuracy of the computed position in some cases). Chip antennas also have very specific ground plane requirements. The antenna vendor can provide assistance in this area and can possibly tune the chip for a specific application.

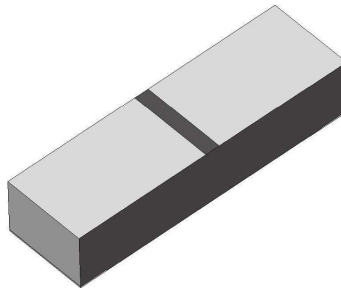

Figure 5 – Chip Antenna

MN5310HS/AHS Design Guidelines



9 Notices

All reference and informational documents (including marketing information, specifications, reference designs, etc.) are provided for information only and are subject to change without notice. Reasonable efforts have been made in the preparation of these documents to assure their accuracy, however Micro Modular Technologies Pte. Ltd. assumes no liability resulting from errors or omissions in this, or any document, or from the use of the information contained herein. Micro Modular Technologies Pte. Ltd. reserves the right to make changes in the product design and specifications as needed and without notification to its users. Please check our website for the most current documentation. All information contained herein is the property of Micro Modular Technologies Pte Ltd. and may not be copied or reproduced, other than for your information, without prior written consent.

10 Contact Information

Email: sales@micro-modular.com

www.micro-modular.com

Asia & Corporate Headquarters

Tel: (65) 6745 8832

Americas and Europe

Tel: (1) 303-482-2842