

MN8010 GPS Receiver Module



1 Description

The Micro Modular Technologies MN8010 Global Positioning System (GPS) Receiver Module is a complete 48-channel receiver with high sensitivity that measures only 10 x 10 x 2 mm. It is a highly integrated, fully autonomous GPS receiver including all baseband and RF circuit functions. The user needs only provide DC power and a GPS signal; the MN8010 will output the navigation solution in the widely-used NMEA-0183 protocol or in One Socket Protocol (OSP).

The MN8010 is able to detect extremely low signal levels, having tracking sensitivity of -163dBm. An integrated LNA allows for easy design with passive antennas, and the LNA may be put in low gain mode for use with active antennas. To help filter out interference, the MN8010 features a jammer remover that can track up to eight jammers. It also includes the option of connecting to external sensors or a serial EEPROM through an I2C port. The MN8010 operates from a single battery supply between 2.5 and 5.0 VDC. For even further power reductions, the OEM design may use a power-saving mode via binary commands.

The MN8010 is supported by an evaluation kit, including software, along with reference designs to speed OEM development. The MN8010 is machine placeable by standard surface mount equipment and is available in tube or tape and reel.

1.1 Features

- Complete SiRFstarIV-based 48-channel GPS receiver
- Highly integrated design includes on-board LNA, TCXO, RF filtering, Reset circuit, and a Real Time Clock circuit with crystal
- Ultra-small 10 x 10 x 2 mm 36-pin LGA package
- Cold-start acquisition sensitivity of -148dBm, tracking -163dBm
- Active Jammer Remover
- Less than 125 mW typical power consumption at 3.3V input
- Industrial temperature operation (-40°C to +85°C)
- Integrated LNA design supports active or passive antennas
- Standard serial protocols: NMEA-0183 or SiRF OSP
- Evaluation Kit available
- Pb free RoHS compliant



1.2 Block Diagram

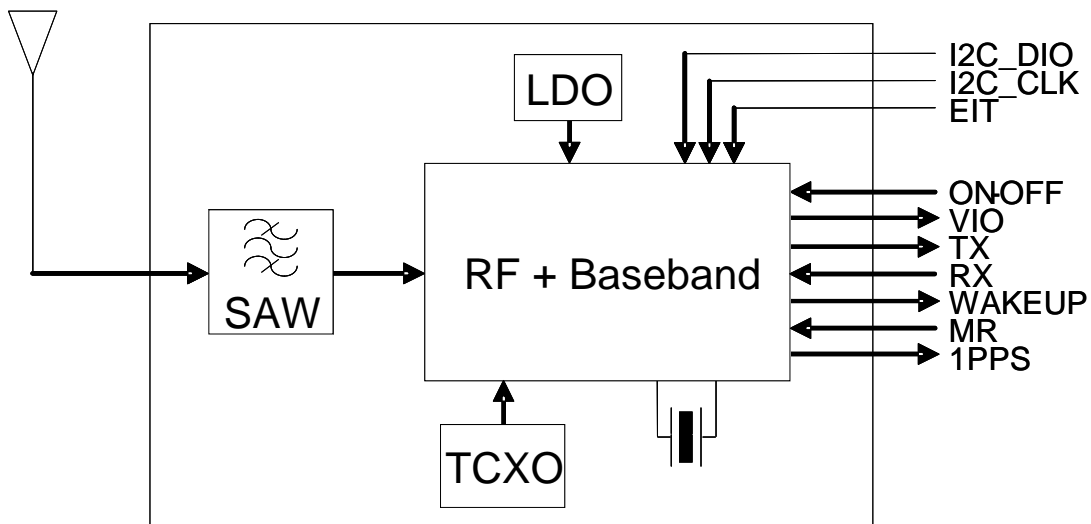

Figure 1 – MN8010 Block Diagram

MN8010

GPS Receiver Module



2 GPS Performance

Parameter	Specification
Acquisition Time	
Cold start TTFF (no time, no position, no ephemeris), typical	<35 seconds
Warm start TTFF (approximate time and position, no ephemeris), typical	<32 seconds
Hot Start TTFF (time, position and ephemeris), typical	<1 second
Horizontal Position Error	
CEP	<2.5 meters
Signal Sensitivity	
Tracking, typical	-163 dBm
Navigation, typical	-160 dBm
Acquisition (Cold Start), typical	-148 dBm
1 Pulse per Second Signal	
1PPS Signal Accuracy	+/-1 uSec
1PPS Signal Offset from UTC 1 Second Epoch	~1 uSec,

Table 1 – GPS Performance Parameters

3 General Specifications

Parameter	Specification
Temperature (operating, storage)	-40°C to +85°C

Table 2 – General Specifications

MN8010

GPS Receiver Module



4 DC Operating Characteristics

V_{DD} is nominally 1.8 VDC.

Parameter	Symbol	Min	Typ	Max	Units
Power Supply Voltage	V_{CC}	2.5		5.0	V
Power Supply Current, Tracking	I_{CC}		38		mA
Shutdown Current (hibernate)	I_{SD}		36		uA
High Level Input Voltage	V_{IH}	$0.7 * V_{DD}$		3.6	V
Low Level Input Voltage	V_{IL}	-0.4		0.45	V
High Level Output Voltage	V_{OH}	$0.75 * V_{DD}$			V
Low Level Output Voltage	V_{OL}			0.4	V
Input Leakage at $V_i=1.8V$ or $0V$	I_i	-10		10	uA
Tristate output leakage at $V_o=1.8V$ or $0V$	I_{oz}	-10		10	uA

Table 3 – DC Operating Characteristics

5 Pin Descriptions

Pin	Name	Description
2	GND	Ground.
3	I2C-DIO	I2C bus data I/O for Dead Reckoning sensors; also serial EEPROM interface.
4	I2C-CLK	I2C bus clock for Dead Reckoning sensors; also serial EEPROM interface.
6	EIT	External interrupt for MN8010.
7	RX	Serial port data input.
8	TX	Serial port data output.
9	1PPS	One-pulse-per-second (1PPS) output.
11	GND	Ground.
12	VIO	1.8 V I/O voltage (output)
22	ON-OFF	Toggles the state of the module between On and Hibernate.
23	MR	External reset input (leave it open, manufacturer use only).
24	GND	Ground.
27	GND	Ground.
29	GND	Ground.
30	RFIN	RF Input.
31	GND	Ground.
32	WAKEUP	Output, low indicates low power state, high indicates active state
33	GPS_3.3V	Primary power supply to the module (+2.5 to +5.0 VDC).

Table 4 – MN8010 Pin-out

Note: The following pins have no internal connection: 1, 5, 10, 13-21, 25, 26, 28, 34-36; input pins are 3.6V tolerant.

MN8010

GPS Receiver Module



6 Power Supply & Power Management

The MN8010 GPS Receiver Module is designed to operate directly from a battery with a supply range of 2.5 volts DC minimum to 5.0 volts DC maximum.

6.1 On-Off Control

Power is controlled via the ON-OFF signal pin (pin 22) of the MN8010. The receiver always powers up in hibernate state. To put the receiver into active operation, host should generate and input a pulse to this pin as shown below in Figure 2 - ON-OFF Signal Timing. After that, the receiver will power up and run continuously while GPS_3.3V is applied. Although GPS_3.3V could be switched off to completely power down the receiver, all data stored in the receiver's RAM will be lost, with the following results:

- Internal TCXO calibration data is lost, lengthening the time for a cold start.
- The current time is lost, eliminating the possibility of a hot start or warm start.
- The current location is lost, eliminating the possibility of a warm start.
- Current ephemeris data is lost, requiring download of the latest ephemeris data.
- Current almanac data is lost so the receiver will revert to the factory almanac.
- Patch RAM contents (if any) are lost and will require a new download.

To place the receiver into hibernate state (all internal power supplies off except RTC and SRAM) from the full power operating (On) state, pulse the On-Off control high for a minimum of 100 milliseconds. To return the receiver to full power operating state from hibernate state, pulse the On-Off control high for a minimum of 100 milliseconds. The Power On-Off pulse must not occur more than once per second.

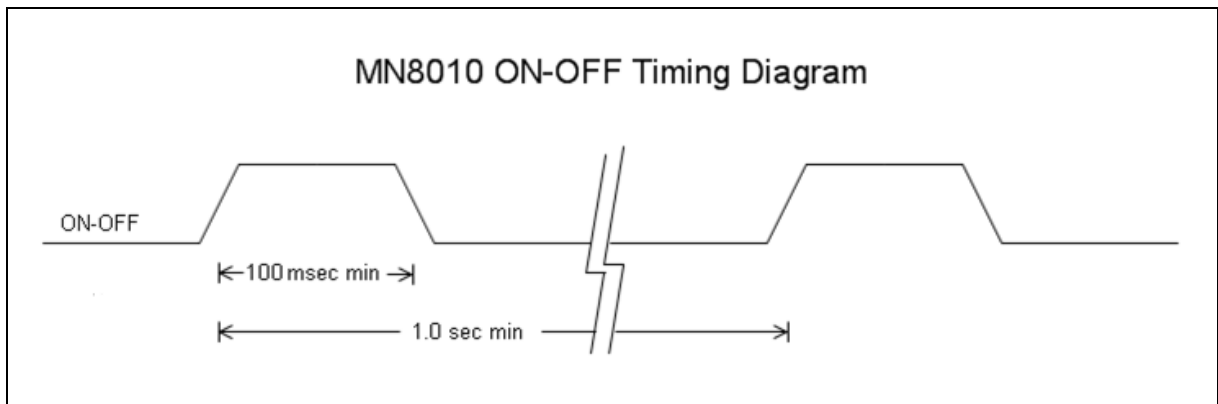

Figure 2 - ON-OFF Signal Timing

If the receiver is operating in one of the power management modes (Adaptive Trickle Power or Push-To-Fix mode), use the software commands to return the receiver to full power operating mode before sending the On-Off pulse. Sending an On-Off pulse during ATP or PTF mode could result in an undetermined power state.

The current power state of the receiver (On vs. Hibernate) can be determined by the level of the WAKEUP pin.

Do not apply an On-Off pulse to the MN8010 if GPS_3.3V is not present.

MN8010

GPS Receiver Module

6.2 VIO Pin

VIO (pin 12) is the output of the internal 1.8 volt I/O regulator. VIO can be used to provide power to an external buffer which would drive the MN8010 RX line. Select a buffer that powers down with high impedance inputs and outputs thereby eliminating the possibility of back-driving the MN8010 through the host side signal output (TX).

VIO can supply no more than 20mA.

7 Digital Signal Interface

7.1 Serial Interface

One full-duplex asynchronous serial data port provides data communications to and from the MN8010 GPS Receiver Module. The default bit rate is standard 4800 baud and the default data format is 8 data bits, no parity, 1 stop bit and no flow control.

RX (pin 7): This signal is the input for the UART and is normally used to input commands or other information to the receiver in either NMEA-0183 or SiRF binary protocol, depending upon the current configuration of the receiver. This signal is a 3.6 volt tolerant CMOS I/O logic level. In the idle condition, this pin should be driven at logic 1. During hibernation and when primary power (VCC) is not present, take care not to drive this line high (the normal default idle state of this signal) to prevent partially powering the MN8010 by back driving the ESD diode protection circuitry. Use the WAKEUP signal to determine whether or not it is safe to drive this line.

Do not hold this line low (BREAK state) while the receiver is active. Its idle state should be HIGH.

If command/data input is not needed, this pin should be open.

TX (pin 8): This signal is the output of the UART and is normally used to output position, time and velocity information from the receiver. This signal is a 1.8 volt CMOS I/O logic level with the idle condition being logic high. The protocol may be either NMEA-0183 or SiRF binary, depending upon the current configuration of the receiver. During hibernation, the TX data line will be at 0 volts. The user is cautioned to ensure that any downstream processing of this signal can tolerate a 0 volt condition (BREAK condition) whenever the MN8010 is in hibernate state. If necessary, the WAKEUP pin can be monitored to determine if the receiver is in hibernate state.

7.2 Pin 3: I2C-DIO

I2C-DIO is dead reckoning I2C bus data (SDA) which supports 400Kbps maximum data rate. It provides connectivity to optional Dead Reckoning sensors (e.g. 3-D Accelerometer). The bus supports also optional connectivity to EEPROM for Client Generated Extended Ephemeris (CGEE) data storage and ROM patch code upload during power up boot and after waking up from Hibernate state of the MN8010HS. This signal requires an external 2.2K ohm pull up resistor and can be left not connected when not used.

7.3 Pin 4: I2C-CLK

I2C-CLK is dead reckoning I2C bus clock (SCL) which supports 400Kbps maximum data rate. It provides connectivity to optional Dead Reckoning sensors (e.g. 3-D Accelerometer). The bus supports also optional connectivity to EEPROM for Client Generated Extended Ephemeris (CGEE) data storage and ROM patch code upload during power up boot and after waking up from Hibernate state of the MN8010HS. This signal requires an external 2.2K ohm pull up resistor and can be left not connected when not used.

MN8010

GPS Receiver Module



7.4 Pin 6: EIT

This pin can be used as a source of a level sensitive interrupt to wake up the MN8010HS from hibernate state. It allows external sensors, e.g. Accelerometer, to provide an interrupt when a change of state is detected. The input can be left not connected when not used.

7.5 Pin 9: 1PPS

The 1PPS signal is a one-pulse-per-second (1PPS) signal. Whenever the receiver provides a valid navigation solution, the rising edge of each 1PPS pulse is synchronized with the UTC one-second epoch. Pulse length (high state) is 200ms about +/-1us accuracy synchronized at rising to full UTC second.

7.6 Pin 22: ON-OFF

This signal is used to control the state of the MN8010HS. This input of the MN8010HS needs to be connected to a push-pull output of a microprocessor.

7.7 Pin 23: MR

This signal is an input to reset the MN8010HS for manufacturer use only. MN8010HS implements internal RESET circuitry so that external control of RESET (Active Low) is not necessary. This pin should be left open (unconnected).

7.8 Pin 32: WAKEUP

This signal output is used to enable an external power management IC. A low on this output indicates that the MN8010HS is in low-power state and a high on this output indicates that the MN8010HS is in full-power state. It can be used externally to switch off the Active Antenna Bias supply voltage during Hibernate state.

MN8010

GPS Receiver Module



8 RF Interface

8.1 RF Input

The MN8010 GPS Receiver Module accepts a GPS L1 C/A signal from an industry-standard GPS antenna (which may be passive or active). If a passive antenna is used, no other circuitry is required. However, if an active antenna is required, then suitable means for powering the active antenna must be provided external to the MN8010 GPS Receiver Module, and also the internal LNA on the GPS receiver IC must be set to Low Gain mode via the Low/High Gain Mode control bit. One option to use the active antenna in High Gain mode would be to add a Pi-network circuit on the RF trace for the desired attenuation. Since the MN8010 can only accept up to +12dB maximum RF input power, then an active antenna with LNA gain of 15dB would require at least 0-3dB attenuation before signal input to the MN8010 (Refer to the MN8010 Design Guidelines for details). The RF input is isolated from DC levels to a maximum of +/- 25 VDC.

If the design is required to supply power for an active antenna, MMT recommends that a quarter wave stub be used to prevent disturbing the matching of the antenna and MN8010 module. The other end of the quarter wave stub should be AC grounded with a suitable microwave quality capacitor.

Signal Level	-163 dBm to -125 dBm typical
Frequency	L1 (1575.42 MHz)
Return Loss	Better than -10 dB
Noise Figure	2 dB typical
Impedance	50 Ohms nominal

Table 5 – RF Signal Characteristics

8.2 LO Leakage

The MN8010 has an internal LO at 1571.424MHz that can appear at the ANT pad of the device. While this level is quite low (approximately -90 dBm), it is high enough that it could interfere with another GPS receiver in the vicinity. This is not a problem in normal operation, but during test and evaluation, several receivers could be operating simultaneously from a common antenna or other signal source. In this case, care must be taken to provide proper isolation between the receivers.

8.3 Spurious Signals

Due to the small size of the MN8010 module and the tight IC geometries used internally, the MN8010 does generate a fair amount of digital noise. Since this is all based upon the internal reference frequency of 16.369 MHz, it is synchronous within the receiver and does not impact receiver operation. However, some signals may interfere with external circuitry. Therefore, it may be necessary to shield the GPS module and related circuitry from other receivers in the end product.

8.4 Burnout Protection

The MN8010 GPS Receiver Module can accept signal levels up to +10 dBm with a DC voltage of +/- 25 V on the RF input pin without permanent damage to the module.

MN8010

GPS Receiver Module



9 Software Interface

9.1 NMEA Data Messages

The MN8010 supports the following NMEA-0183 v3.0 messages by default :

ID	Description	Default interval
GGA	GPS fix data	1 sec
GSA	DOP and active satellites	1 sec
GSV	Satellites in view	5 sec
RMC	Recommended Minimum GNSS Data	1 sec

Table 6 – NMEA Messages

For detailed information regarding these messages, please refer to the SiRF NMEA Reference Manual.

9.2 NMEA Proprietary Commands

The MN8010HS recognizes the following NMEA proprietary commands:

ID	Description
\$PSRF100	Set Serial Port
\$PSRF101	XYZ Navigation Initialization
\$PSRF103	Query/Rate Control
\$PSRF104	LLA Navigation Initialization
\$PSRF106	Select Datum

Table 7 – Proprietary NMEA Commands

For detailed information regarding these commands, please refer to the “SiRF NMEA Reference Manual.”

9.3 SiRF One Socket Protocol (OSP) Messages and Commands

For detailed information regarding the OSP protocol, please refer to the “SiRF One Socket Protocol Interface Control Document including SiRF Binary Protocol Reference Manual.”

10 Referenced Documents

SiRF NMEA Reference Manual
SiRF One Socket Protocol Interface Control Document including SiRF Binary Protocol Reference Manual
MN8010 Design Guidelines

Table 8 – Referenced Documents

MN8010 GPS Receiver Module



11 Packaging and Marking Information

11.1 Component Marking

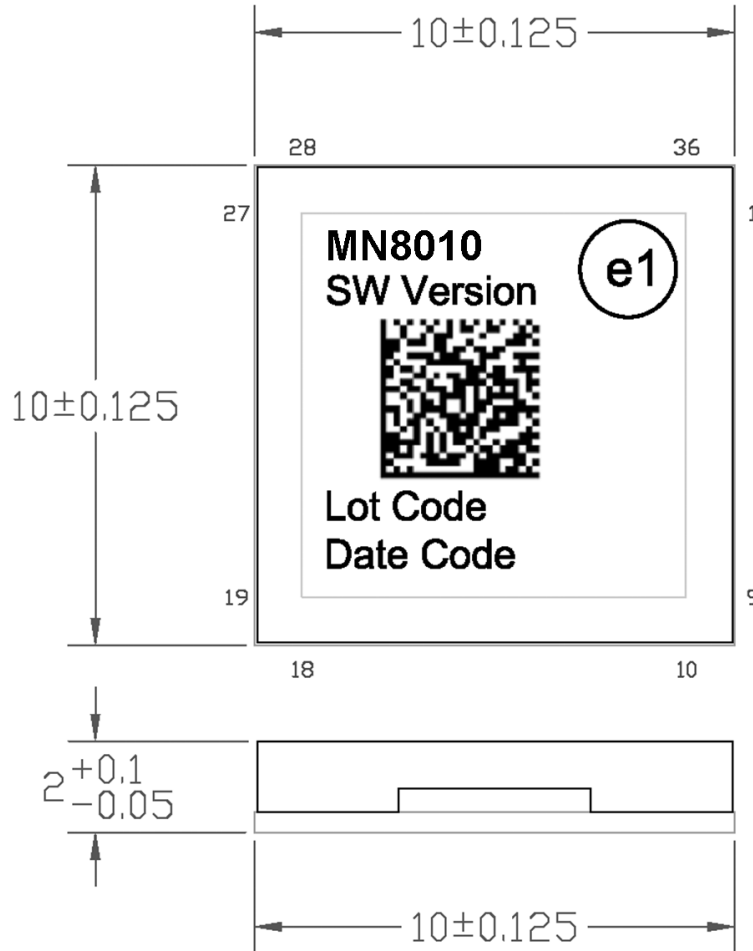

Figure 3 – Package Outline & Marking, top view (mm): 36-pin LGA

Note the JEDEC Pb-free symbol is also used as the pin 1 identifier for the MN8010

11.1.1 Date Code

The date code is contained in the fourth line of text. The first character shall be a number indicating the last digit of the year of manufacture, starting from 2005 to 2014. The second character shall be an alphanumeric character indicating the month of manufacture (see Table 9 – Date Code: Second Character (month indicator)). The third character shall be an alphanumeric character indicating the day of manufacture (see Table 10 – Date Code: Third Character (day indicator)).

1 = January	4 = April	7 = July	A = October
2 = February	5 = May	8 = August	B = November
3 = March	6 = June	9 = September	C = December

Table 9 – Date Code: Second Character (month indicator)

MN8010

GPS Receiver Module



1 = 01	6 = 06	B = 11	G = 16	M = 21	T = 26
2 = 02	7 = 07	C = 12	H = 17	N = 22	U = 27
3 = 03	8 = 08	D = 13	J = 18	P = 23	W = 28
4 = 04	9 = 09	E = 14	K = 19	Q = 24	X = 29
5 = 05	A = 10	F = 15	L = 20	R = 25	Y = 30
					Z = 31

Table 10 – Date Code: Third Character (day indicator)

11.2 Recommended PCB Footprint

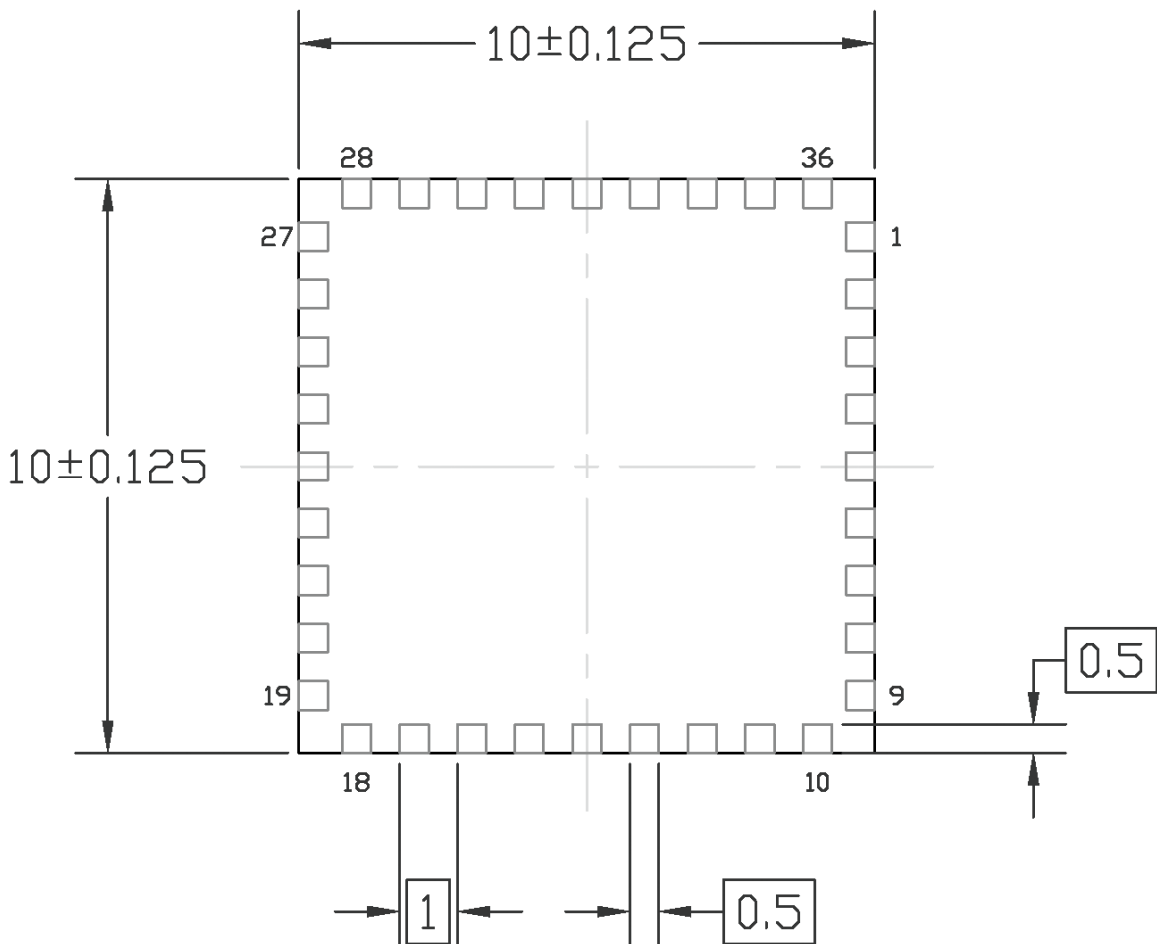

Figure 4 – Recommended PCB Footprint (in mm) – Top View

Figure 4 is a suggested PCB footprint for the MN8010. The user may need to adjust the pad dimensions based upon their manufacturing process. While solder mask covered traces are permissible underneath the MN8010, exposed vias or pads should be avoided.

11.3 Recommended Reflow Profile

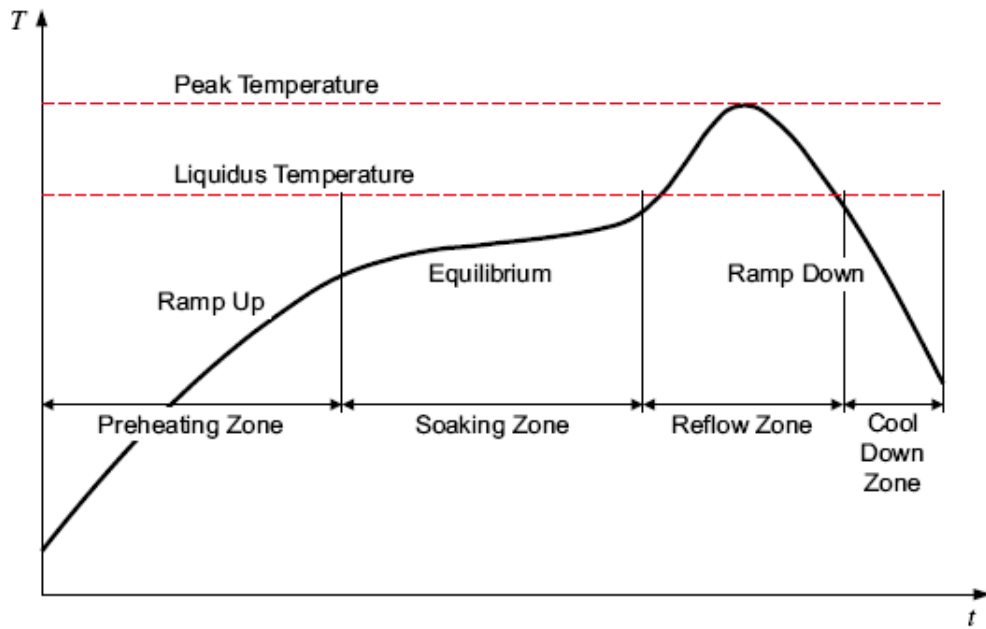

Figure 5 – Reflow Profile

Reflow Parameter	Specification
Preheating Rate	2.5°C/second
Soaking Temperature	140°C to 170°C
Soaking Time	80 seconds
Peak Temperature	260°C
Reflow Time over Liquidus	60 seconds
Cool down Rate	2.5°C/second

Table 11 – Reflow Parameters

MN8010 GPS Receiver Module



12 Ordering Information

The ordering part numbers are contained in the table below:

Ordering Part Number	Description
MN8010-BS	MN8010 in trays

Table 12 – Ordering Information

13 Notices

All reference and informational documents (including marketing information, specifications, reference designs, etc.) are provided for information only and are subject to change without notice. Reasonable efforts have been made in the preparation of these documents to assure their accuracy, however Micro Modular Technologies Pte. Ltd. assumes no liability resulting from errors or omissions in this, or any document, or from the use of the information contained herein. Micro Modular Technologies Pte. Ltd. reserves the right to make changes in the product design and specifications as needed and without notification to its users. Please check our website for the most current documentation. All information contained herein is the property of Micro Modular Technologies Pte. Ltd. and may not be copied or reproduced, other than for your information, without prior written consent.

14 Contact Information

Email: sales@micro-modular.com

www.micro-modular.com

Asia & Corporate Headquarters

Tel: (65) 6745-8832

Americas and Europe

Tel: (1) 949-336-7850